

UTTERMOST

ASSEMBLY INSTRUCTIONS

ITEM.: 24400

Step 1



1. Take the parts carefully out of carton, and then place them on a flat and soft surface, making sure that parts will not be damaged. When assembling install all bolts before securing any one bolt.

2. Place small-top 1 upside down; Place the large-top 2 on the small top 1 upside down, Align hole A on the base with hole A on the top (as shown in the figure);

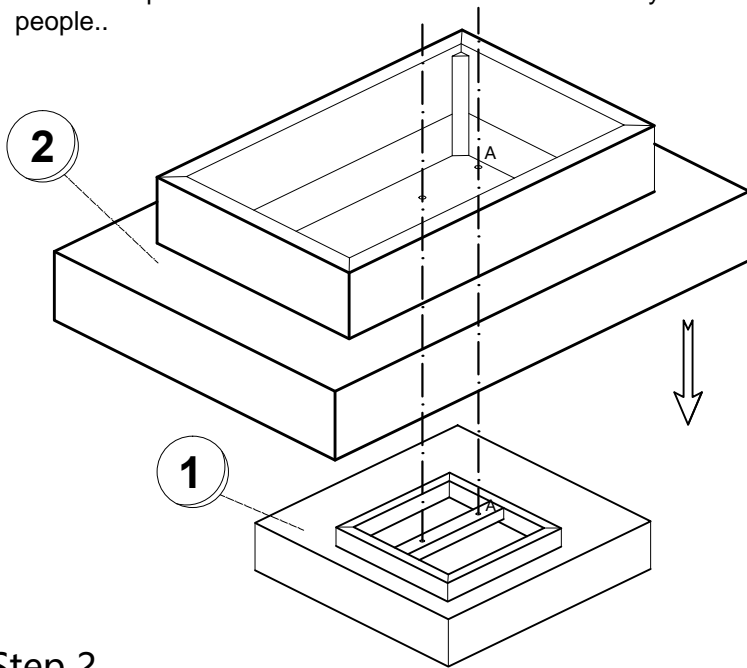



Note: This product needs to be lifted and assembled by 2 or 3 people..



PART LIST

NO.	DESCRIPTION	QTY
1	TOP-Small 	1 PC
2	BASE-Bigger 	1 PC

HARDWARE

A	Bolt 	2 pcs
B	Lock washer 	2 pcs
C	Flat washer 	2 pcs
D	Allen wrench 	1 pc

Step 2

Fix the Top (1) and BASE (2) with Bolt (D, A, B, C), and tight.

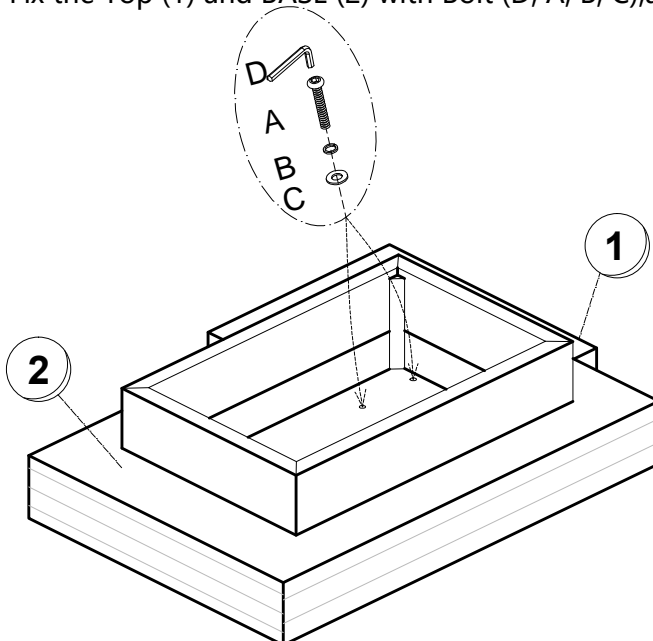

Step 3

Turn over the table and the assembly is complete.

