











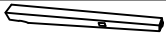

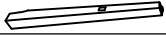

UTTERMOST

ASSEMBLY INSTRUCTIONS

ITEM: 23883

PARTS LIST							
NO	DRAWING	PARTS NAME	Q'TY	NO	PARTS NAME	DRAWING	Q'TY
A		FLAT WASHER 5/16"*3/4"	8PCS	1	SEAT FRAME		1PC
B		LOCK WASHER 5/16"	8PCS	2	RIGHT FRONT LEG		1PC
C		BOLTS DIA 5/16"*1-3/4"	4PCS	3	LEFT FRONT LEG		1PC
D		BOLTS DIA 5/16"*2-1/4"	4PCS	4	RIGHT BACK LEG		1PC
E		ALLEN WRENCH 5/16"	1PC	5	LEFT BACK LEG		1PC
F		WOOD SCREW 2"	8PCS	6	LEFT SIDE STRETCHER		1PC
				7	RIGHT SIDE STRETCHER		1PC
				8	FRONT STRETCHER		1PC
				9			1PC

ASSEMBLY BOLTS MAY NEED TIGHTEND AFTER USE

STEP 1

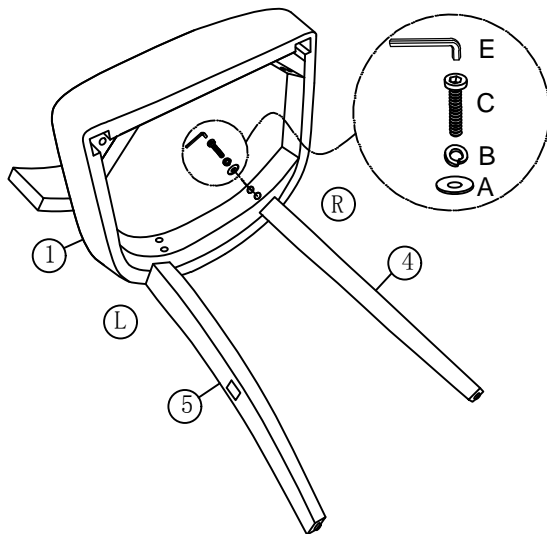

STEP 2

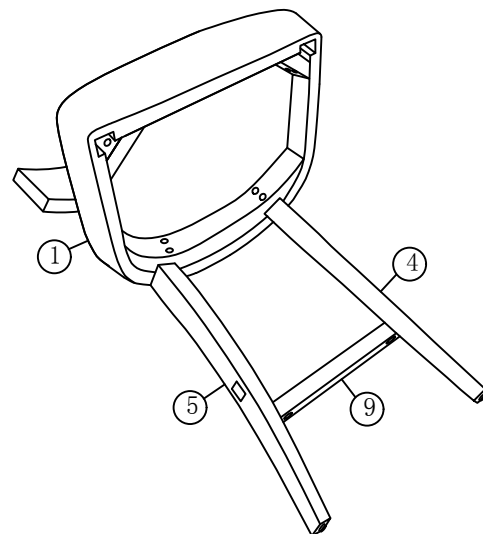

NOTE : Leave BOLTS loose by 1/4 turn when securing LEGS until after STEP 5.

NOTE : Do not add WOOD SCREWS (F) until STEP 5 .

re- tighten the leg bolts after using a period of time

To avoid wobbly product and gaps between legs and stretchers, please follow below steps to assemble:

- 1) Attach the legs. Do not completely tighten the bolts that hold the legs.
- 2) Attached the stretchers. Completely tighten the screws that hold the stretchers.
- 3) Set the chair on the floor to level and then finish tightening the leg bolts

UTTERMOST

ASSEMBLY INSTRUCTIONS

ITEM:23883

STEP 3

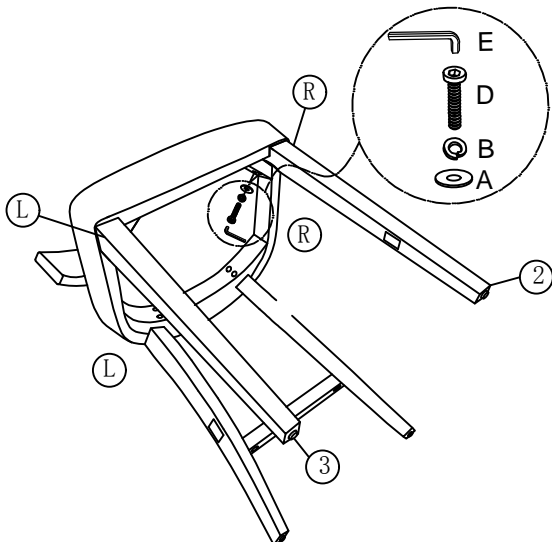

NOTE : Leave BOLTS loose by 1/4 turn when securing LEGS until after STEP 5.

STEP 4

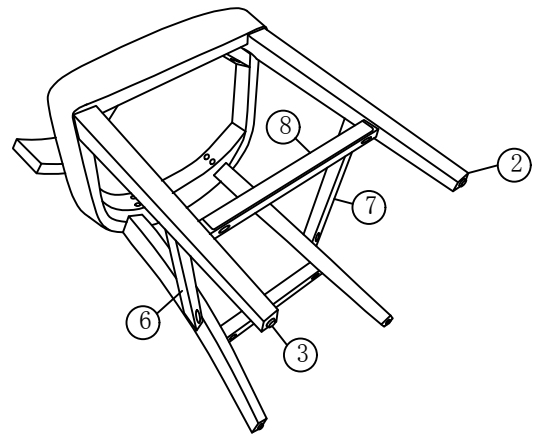

NOTE : Do not add WOOD SCREWS (F) until STEP 5 .

STEP 5 Using a PHILLIPS HEAD SCREW DRIVER and Wood SCREW (F) tighten all Stretchers securely . DO NOT OVERTIGHTEN .

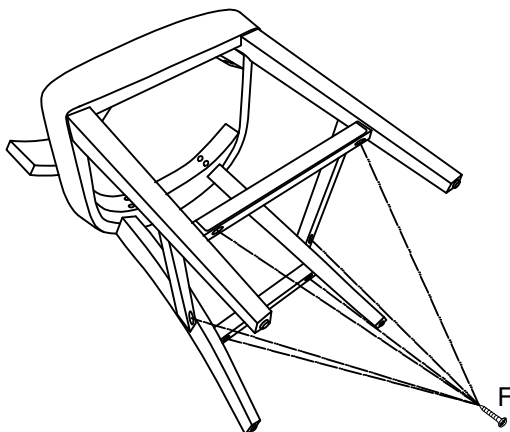

STEP 6

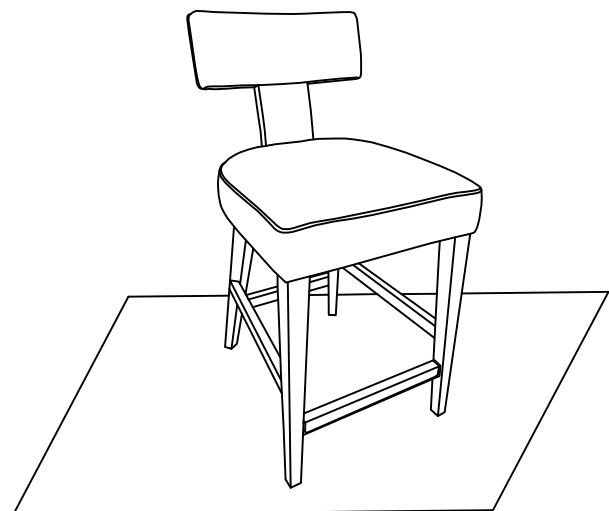

re- tighten the leg bolts after using a period of time

To avoid wobbly product and gaps between legs and stretchers, please follow below steps to assemble:

- 1) Attach the legs. Do not completely tighten the bolts that hold the legs.
- 2) Attached the stretchers. Completely tighten the screws that hold the stretchers.
- 3) Set the chair on the floor to level and then finish tightening the leg bolts