









# UTTERMOST

## ASSEMBLY INSTRUCTIONS

ITEM:23163

PARTS LIST							
NO	DRAWING	PARTS NAME	Q'TY	NO	PARTS NAME	DRAWING	Q'TY
A		FLAT WASHER 5/16" * 3/4"	8PCS	1	SEAT FRAME		1PC
B		LOCK WASHER 5/16"	8PCS				
C		BOLTS DIA 5/16" * 2"	4PCS	2	FRONT LEG		2PCS
D		BOLTS DIA 5/16" * 2-1/2"	4PCS				
E		ALLEN WRENCH 5/16"	1PC	3	BACK LEG		2PCS

ASSEMBLY BOLTS MAY NEED TIGHTEND AFTER USE

STEP 1

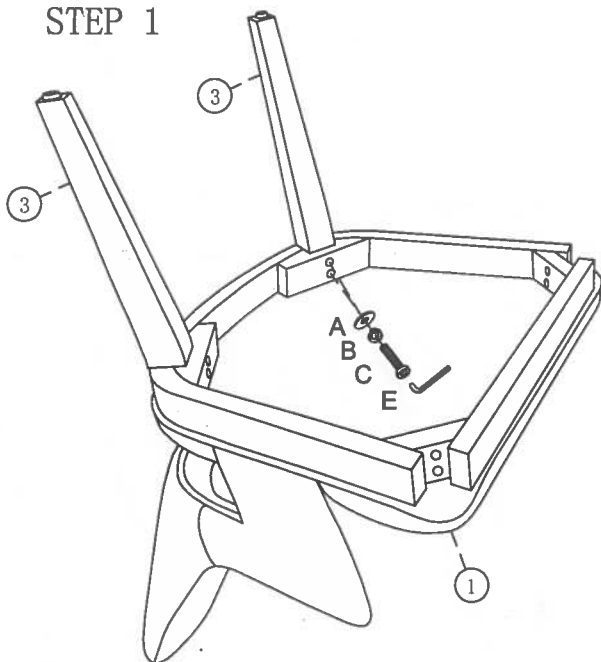

STEP 2

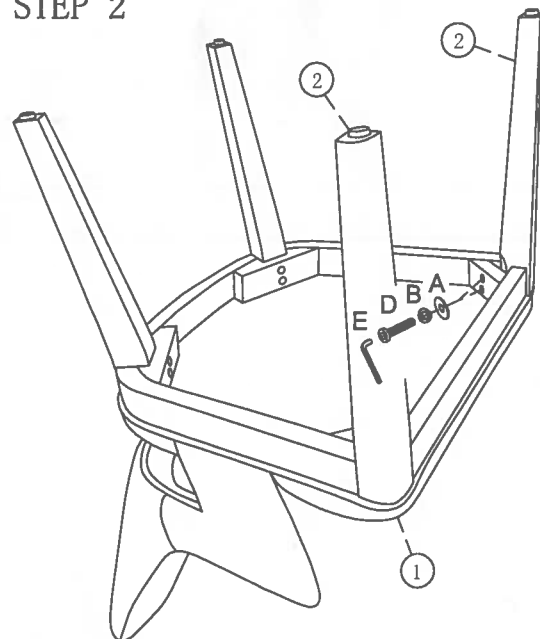

STEP 3

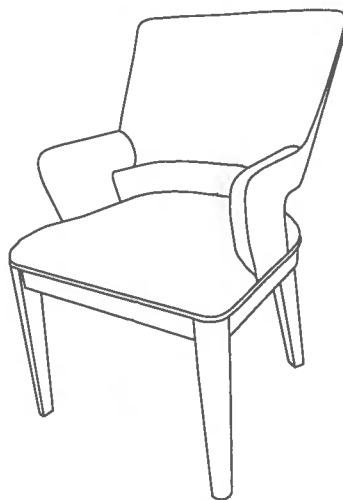

**re-tighten the leg bolts after using a period of time**

To avoid wobbly product , please follow below steps to assemble:

- 1) Attach the legs. Do not completely tighten the bolts that hold the legs.
- 2) Set the chair on the floor to level and then finish tightening the leg bolts.